

Model C2240 Carton Combiner



Carton Combiner unitizes multiple cartons together at 224 cpm.

Pearson's C2240 Carton Combiner is a high speed, compact, automatic machine capable of applying glue or tape to multiple cartons to form single units for palletizing. Continuous motion allows the machine to run at speeds up to 224 cartons per minute.

Cartons enter the C2240 back to back with their broad side leading. A servo driven metering section accumulates the cartons and controls them as the cartons are metered into the machine. As the cartons move through the glue station, glue beads are applied to the trailing carton. After glue is applied, the cartons move onto a flighted belt that forces cartons together, allowing the glue to set and combine the cartons into single units. After being combined, the units are discharged from the machine.

The C2240 features optional tape combining that applies tape to the tops and bottoms of combined

cartons. The C2240 can also be run in bypass mode allowing cartons to move through the machine without being glued or taped.

The C2240 features stainless steel construction with washdown components, Allen-Bradley® Variable Frequency Drives, Allen-Bradley® PanelView, Nordson® ProBlue glue unit, Nema 4 Electrical Components, Allen-Bradley® CompactLogix PLC, and light curtain guarding around the perimeter of the machine for optimum floor space savings & machine accessibility. The C2240 can be configured for either right or left hand operation.

Like all Pearson products, the C2240 is backed by Pearson's experienced factory professionals as well as one of the largest teams of PMMI certified regional service technicians in the industry, available 24-hours a day, 7-days a week - worldwide.

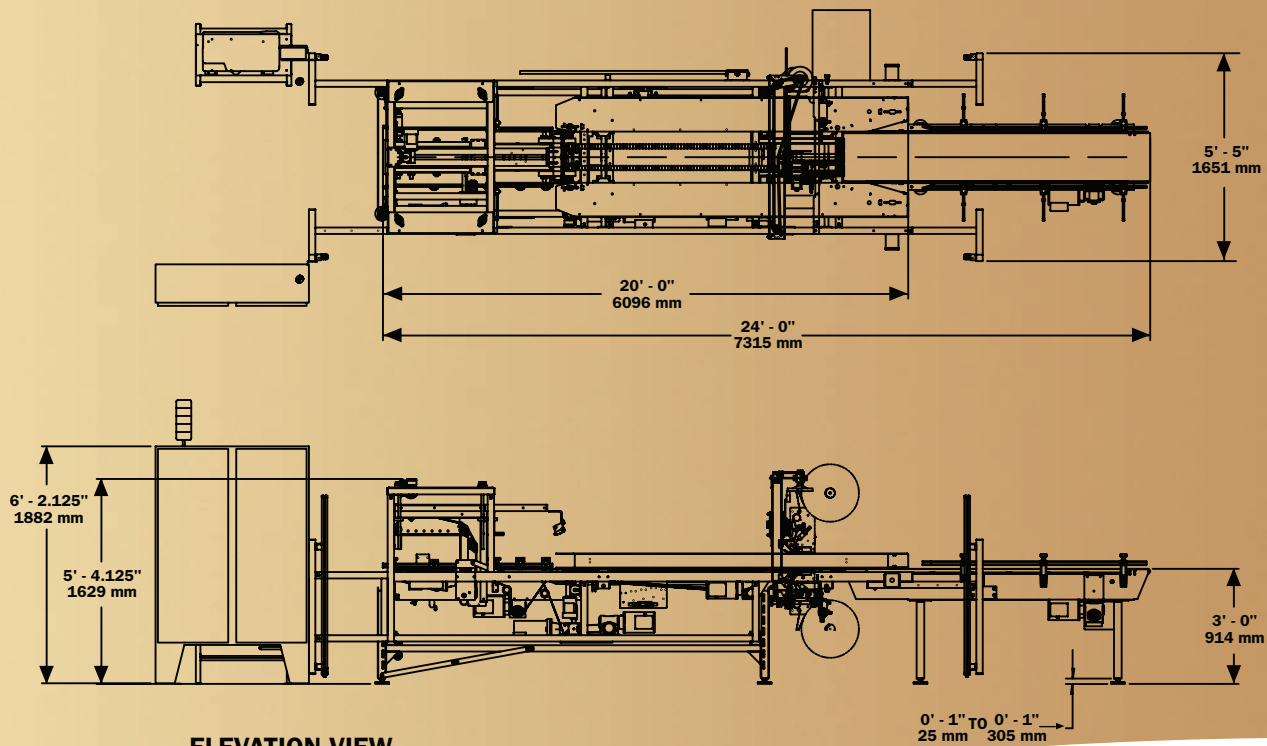

ELEVATION VIEW

UTILITY REQUIREMENTS C2240

Electrical:

230/460V, 3-phase,
60 Hz Std., 13.8 kVA

Pneumatic:

3.0 SCFM @ 80 PSI
(0.085 m³/minute @ 551.2 KPa)

Shipping Weight:

3940 lbs (1789 kg)

CARTON RANGE

LENGTH*	WIDTH*	HEIGHT*
10" – 15.75" 254 – 400 mm	10.5" – 16" 267 – 406 mm	3.25" – 12" 834 – 305 mm

MACHINE SIZE

LENGTH	WIDTH	HEIGHT
23' – 11.3125" 7298 mm	4' – 8.5" 1435 mm	7' – 6" 2286 mm

* Indicates carton size range - length dimensions are combined length - product length and combined product pattern must be verified by Pearson engineering.

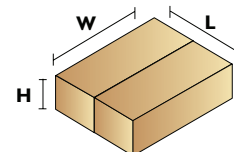

2 2x6 cartons

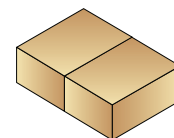

2 3x4 cartons

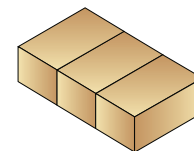

3 2x4 cartons

Pearson's Winning Formula!

- Designed for round the clock operation.
- Stainless steel and wash down components construction.
- NEMA 4 Electrical components.
- Allen-Bradley® Variable Frequency Drives.
- Allen-Bradley® CompactLogix PLC.
- Nordson® ProBlue glue unit.
- Allen-Bradley® PanelView.
- Light curtain guarding for floor space savings and improved machine access.
- Machine can be configured for right or left hand operation.
- Easily handles pass through for no glue or tape applications.
- Expert after-sale service and 24 hour technical support.

