

# Model CS25 Case Sealer Patented

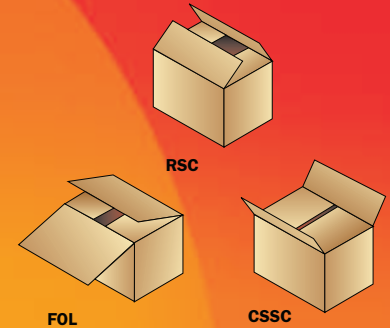

## New Case Sealer top seals cases at speeds up to 25 CPM.

Pearson Packaging Systems CS25 Case Sealer top seals cases with either pressure sensitive tape or hot melt adhesive at speeds up to 25 cpm for the full standard case range. The CS25 is available in mild steel or stainless steel construction.

The CS25 is a fully guarded, rugged, compact, and automatic machine capable of top sealing a wide range of RSC, FOL & CSSC corrugated cases. The side belt drive with its Compensating Independent Roller System (patented) provides smooth and reliable case transfer for cases up to 13.5 Kg (30 lbs). The Synchronous Drive System eliminates the need for complicated chain tensioning or multiple shafts and gear reducers.

The CS25 utilizes continuous motion to achieve 25 cpm across the full standard case range. Faster

case speeds are possible on shorter length cases. The CS25 also utilizes no tool quick change over to different case sizes. Filled cases enter the machine with a minimum of 380mm (15 in) separation. Minor & major flaps are folded and a Dekka® tape head applies tape or a Nordson® Adhesive Melter applies glue to the case. The CS25 comes standard with 24VDC control voltage, UL® Listed Control Panel, Allen-Bradley® PLC, PackML compliance and non-lube bearings.

Like all Pearson products, the CE25 is backed by Pearson's experienced factory professionals as well as one of the largest teams of PMMI certified regional service technicians in the industry, available 24-hours a day, 7-days a week - worldwide.

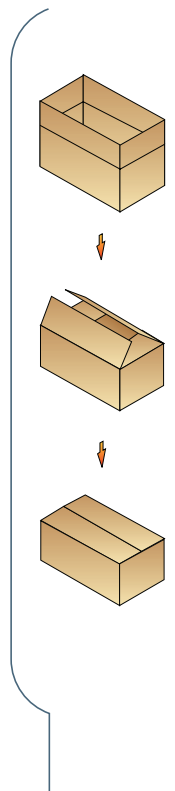

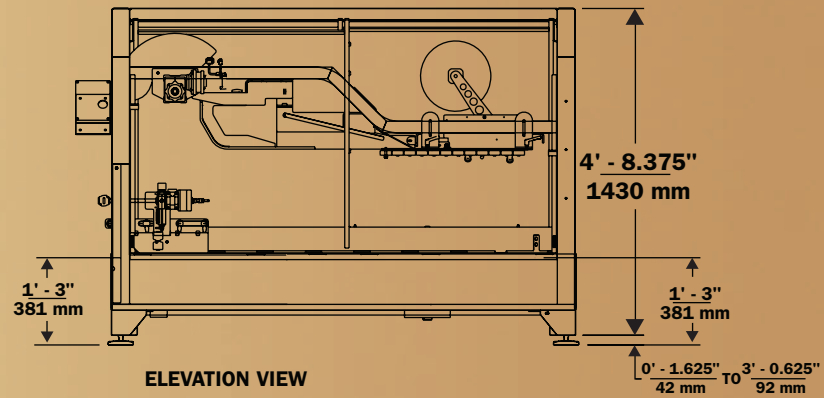
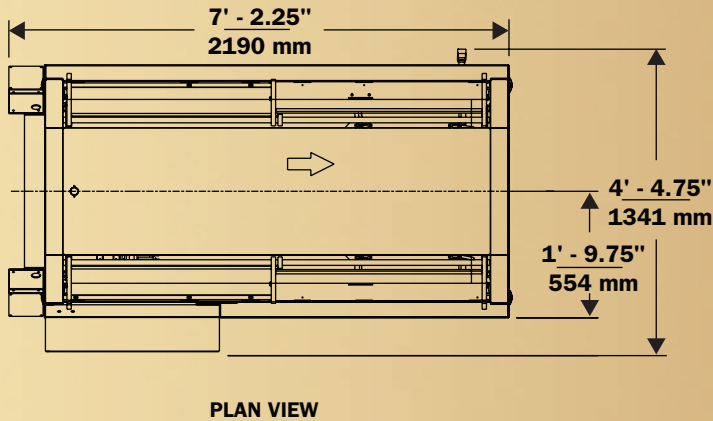

### UTILITY REQUIREMENTS CS25

**Electrical:**

230/460V, 3-phase,  
60 Hz Std., 1.5 kVA

**Pneumatic:**

0.064 SCF/Cycle @ 80 PSI  
(0.002 m<sup>3</sup> /cycle @ 551.2 KPa)

**Shipping Weight:**

1434 lbs (650 kg)

ERECTED CASE SIZE RANGES					
	LENGTH	WIDTH	OPEN DEPTH*	CLOSED DEPTH	FLAP LENGTH
<b>CS25-T</b>	8" – 24"	5" – 16"	7" – 22.75"	4.5" – 18.5"	2.5" – 8"
<b>CS25-G</b>	204 – 609 mm	127 – 406 mm	178 – 578 mm	114 – 469 mm	64 – 203 mm
<b>Maximum Case Weight is 30lb (13.5 kg)</b>					
* Top flaps open, bottom flaps closed. For speeds greater than 25 cpm, please consult the factory.					

### Pearson's Winning Formula!

- Rugged, compact, continuous motion case sealer.
- 25 cases per minute for the full standard case range with faster speeds possible on shorter case lengths.
- Available in mild steel or stainless steel construction.
- No tool quick change over to different case sizes.
- Compensating Independent Roller System for smooth & reliable case transfer through the machine (patented).
- Synchronous Drive System standard.
- Externally accessible adjustments.
- Allen-Bradley® PLC standard.
- PackML compliant standard.
- Pneumatic controlled flap kicker.
- Full perimeter guard package with safety interlocks.
- Dekka® Pressure Sensitive Tape Head or Nordson® Adhesive Melter available.
- NEMA 4 electrical enclosure.
- Expert after-sale service and 24 hour technical support.

MACHINE SPECIFICATIONS			
	LENGTH	WIDTH	HEIGHT
<b>CS25-T</b>	7' - 2.25"	4' - 4.75"	4' - 8.375"
<b>Pressure Sensitive Tape</b>	2190 mm	1341 mm	1430 mm
<b>CS25-G</b>	7' - 2.25"	4' - 4.75"	4' - 8.375"
<b>Hot Melt Adhesive</b>	2190 mm	1341 mm	1430 mm

