

Model FS50 Flap Slitter

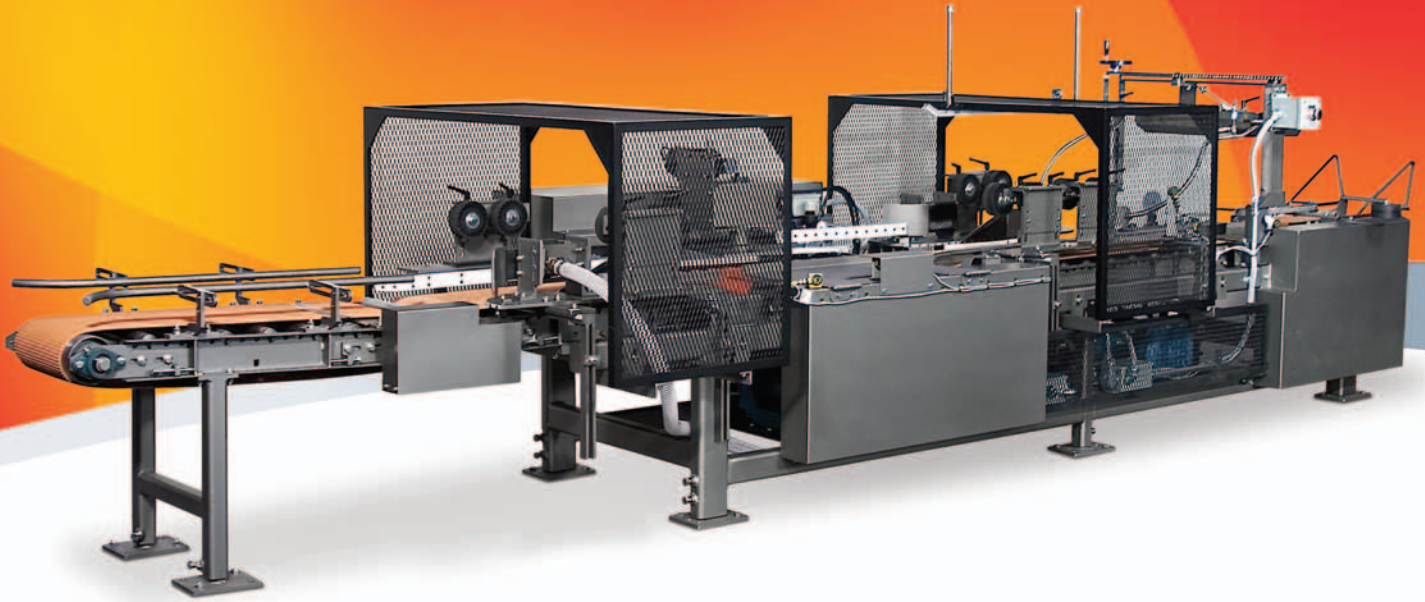

Adjustable Flap Slitter Cuts Tablock Cases at rates up to 50 cpm.

Pearson's Model FS50 Adjustable Flap Slitter is designed to automatically sever RSC Tablocks at speeds up to 50 cases per minute. This machine is complete with positive case control, flap pulling plenum kit for second flap slitting station, inventory control photoeye and a UL® Listed Control Panel. The FS50-SL is also available. The FS50-SL slits RSC Tablocks and then sends the cases to be sealed with either tape or glue.

The FS50-45 Large Frame Adjustable Flap Slitter is also available at speeds of 45 cases per minute.

Designed to sever the tablocks on large cases, the FS50-45 Large Frame machine comes complete with positive case control, flap pulling plenum kit for the second flap slitting station, inventory control photoeye and UL® Listed Control Panel.

Like all Pearson products, the FS50 is backed by Pearson's experienced factory professionals as well as one of the largest teams of PMMI certified regional service technicians in the industry, available 24-hours a day, 7-days a week - worldwide.

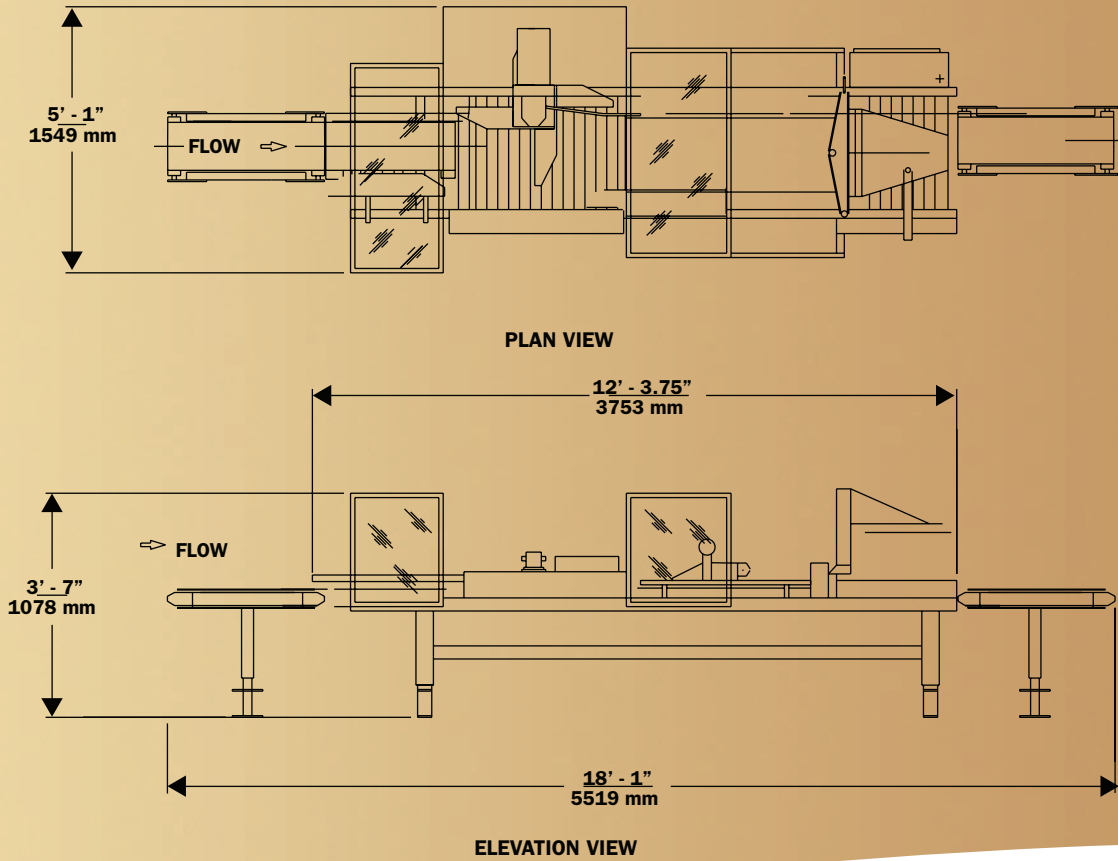

UTILITY REQUIREMENTS FS50

Electrical:
230/460V, 3-phase,
60 Hz Std., 1.5 kVA

Shipping Weight:
2750 lbs. (1238 kg)

ERECTED CASE SIZE RANGES

LENGTH	WIDTH	DEPTH
12" - 19"	8.5" - 12"	4.5" - 17.5"
305 - 483 mm	216 - 305 mm	114 - 445 mm

